

NEW 

CAIS E-BOX "M" 6.0 + 8.0

CANTILEVER HARDWARE

E-BOX "M"

E-BOX "M" 6.0

SET

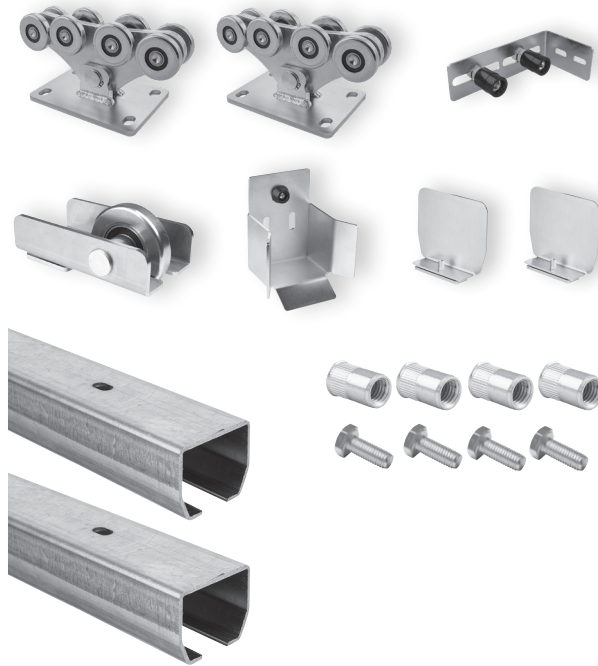

SPEED ME2 pcs
 STAGE MZ 2,85.....3 pcs
 RUN M1 pc
 LAST M1 pc
 PILOT MN2 pcs
 FRM 21 pc
 PARK CSM1 pc
 BOLT M10x2524 pcs
 RIVET NUT24 pcs

ART. SET / kg

E-BOX "M" 6.0.....127,1kg

GATES UP TO

LENGHT 6 m

CODE: 1710077

E-BOX "M" 8.0

SET

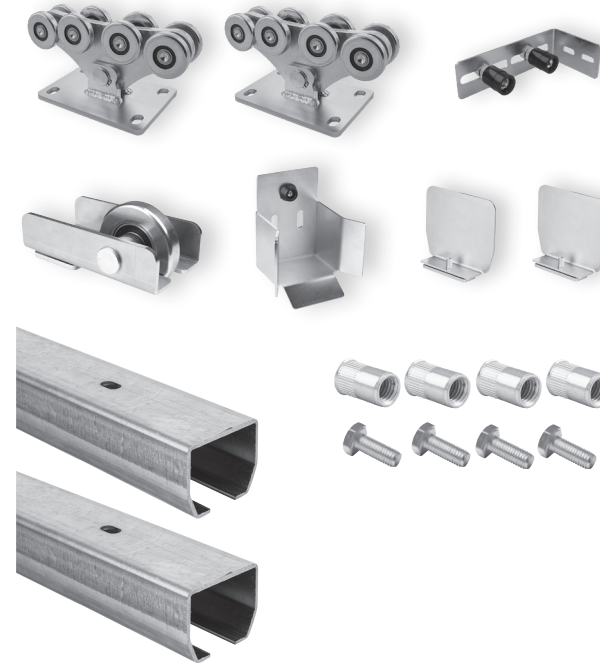

SPEED ME2 pcs
 STAGE MZ 2,85.....4 pcs
 RUN M1 pc
 LAST M1 pc
 PILOT MN2 pcs
 FRM 21 pc
 PARK CSM1 pc
 BOLT M10x2532 pcs
 RIVET NUT32 pcs

ART. SET / kg

E-BOX "M" 8.0.....158,4kg

GATES UP TO

LENGHT 8 m

CODE: 1710078

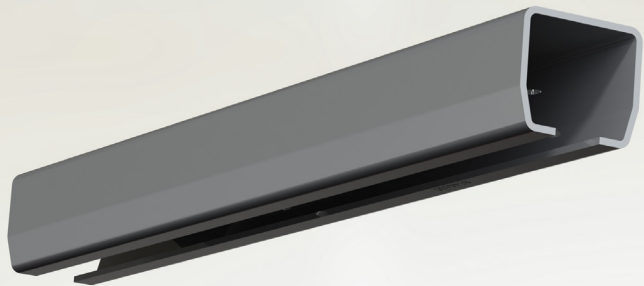

W Wuppermann
GERMAN STEEL

GALVANIZED
INTERNAL
EDGES



270
g/m²

HOT
DIPPED
GALVANIZED

SPECIAL
THICKNESS

5,00
mm



- 37°C
TESTED
& PROVEN



+ 50°C
TESTED
& PROVEN



24
months

24 MONTHS
TESTED
& PROVEN



MADE IN
CZECH
REPUBLIC



BOLTS
RIVET NUTS
INCLUDED (*)



SLOTTED HOLE
PUNCHED EVERY
400mm IN TRACK



SERIAL NUMBER
CARRIAGE
TESTED & PROVEN



EASY
ASSEMBLY



FAST
NO WELDING
REQUIRED

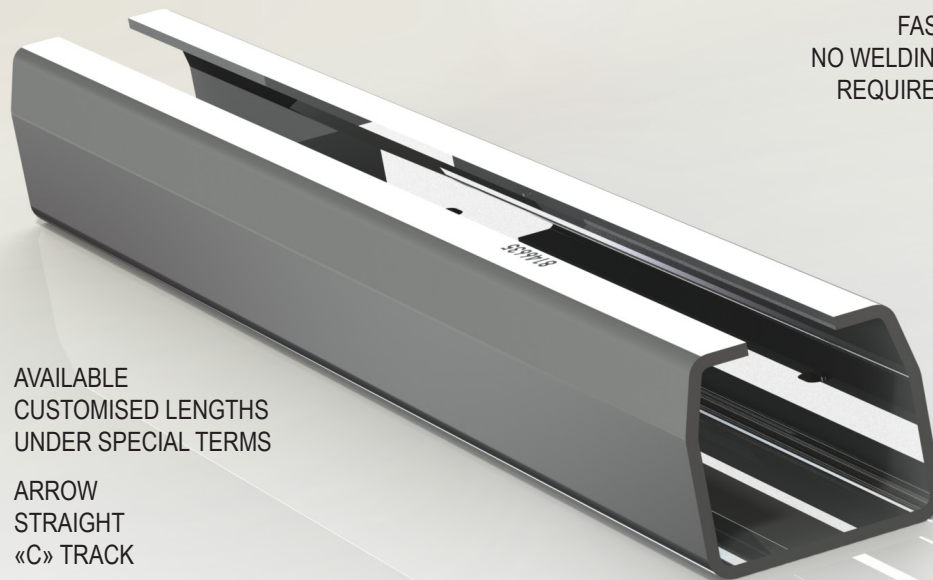

AVAILABLE
CUSTOMISED LENGTHS
UNDER SPECIAL TERMS



ARROW
STRAIGHT
«C» TRACK

18

EIGHTEEN ROLL FORMERS
THE LARGEST NUMBER IN THE INDUSTRY
REMOVE THE INSET «MEMORY» OF THE STEEL



SLOW ROLLING
NO HEAT GENERATED DURING PRODUCTION
KEEPING THE MATERIAL WHERE IT IS ROLLED









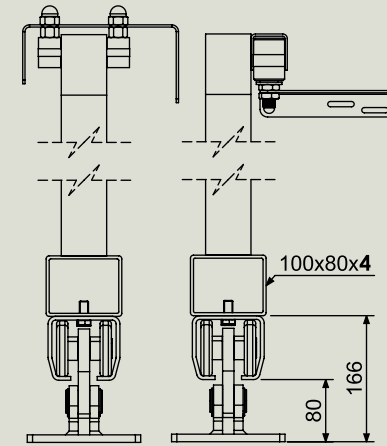









R&D



BRNO
UNIVERSITY
OF TECHNOLOGY

CANTILEVER M									
	mm; kg	mm; kg	mm; kg	mm; kg	mm; kg	mm; kg	mm; kg	mm; kg	mm; kg
A	4000	4500	5000	5500	6000	6500	7000	7500	8000
max. weight gate	500 kg	525 kg	550 kg	575 kg	600 kg	625 kg	650 kg	675 kg	700 kg
B	1200	1350	1500	1650	1800	1950	2100	2250	2400
C	1860	2010	2160	2310	2460	2610	2760	2910	3060
D	330	330	330	330	330	330	330	330	330



-  EASY ASSEMBLY
-  FAST NO WELDING REQUIRED
-  BOLTS RIVET NUTS INCLUDED (*)
-  «C» TRACK SERIAL NO. 100% COMPATIBILITY CARRIAGE TESTED
-  GERMAN STEEL
-  270 g/m² HOT DIPPED GALVANIZED
-  ARROW STRAIGHT «C» TRACK
-  SLOTTED HOLE PUNCHED EVERY 400mm IN TRACK
-  GALVANIZED INTERNAL EDGES
-  MADE IN CZECH REPUBLIC
-  C 2 HIGH QUALITY BEARINGS
-  CARRIAGES CENTER HOLES MILLED NOT LASER CUT
-  MULTI RIVETED SECTIONS
-  JAPANESE ROBOTICS FANUC
-  UNIVERSITY OF TECHNOLOGY – BRNO
-  - 37°C TESTED & PROVEN
-  + 50°C TESTED & PROVEN
-  NO WELDING REQUIRED

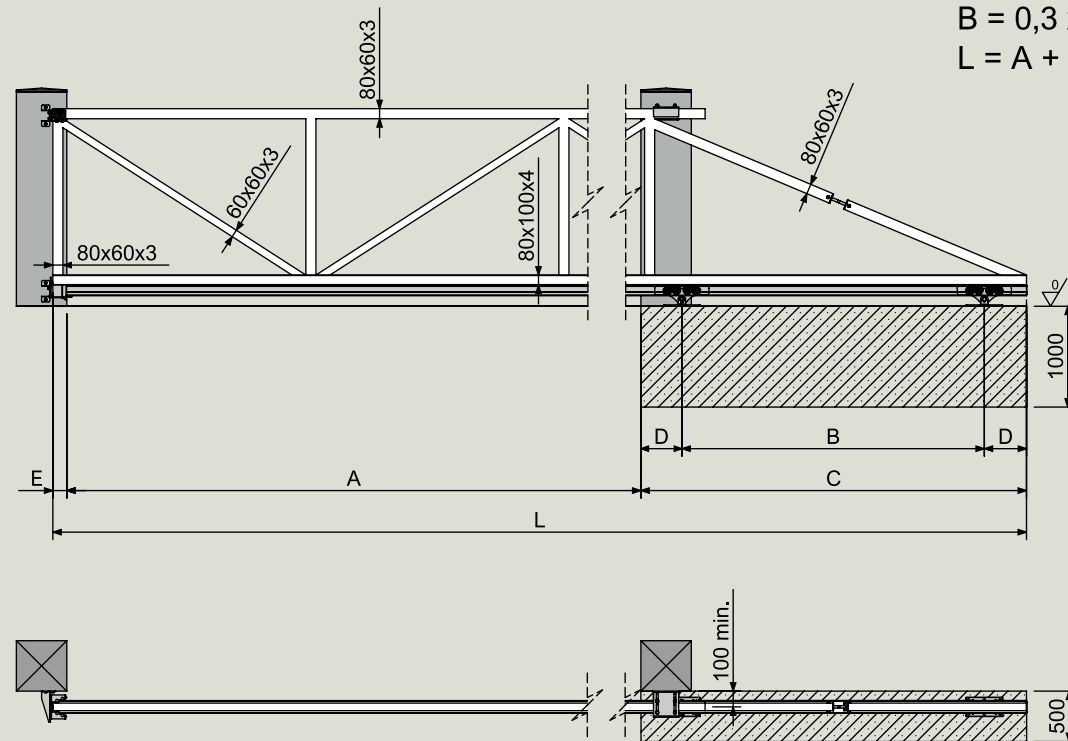

CAIS MANUAL

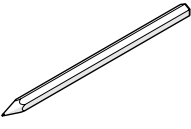
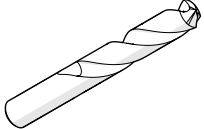
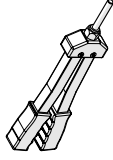
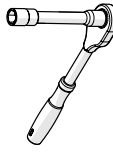
			
Pencil	Drill bit 13mm	Riveting pliers	Ratchet 17 mm

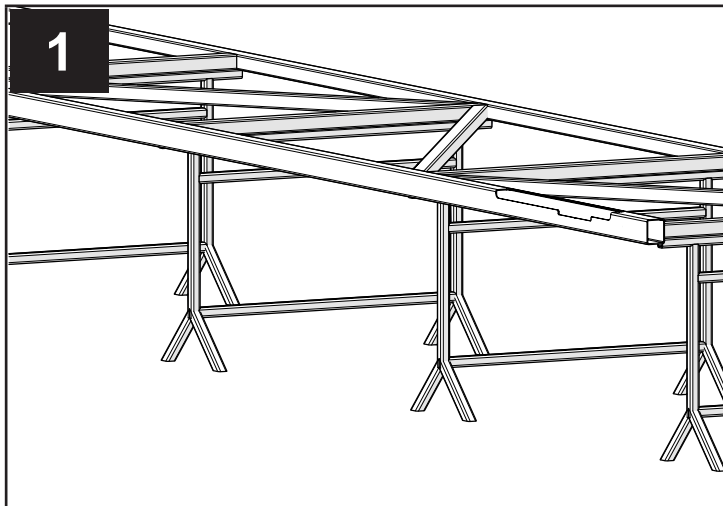
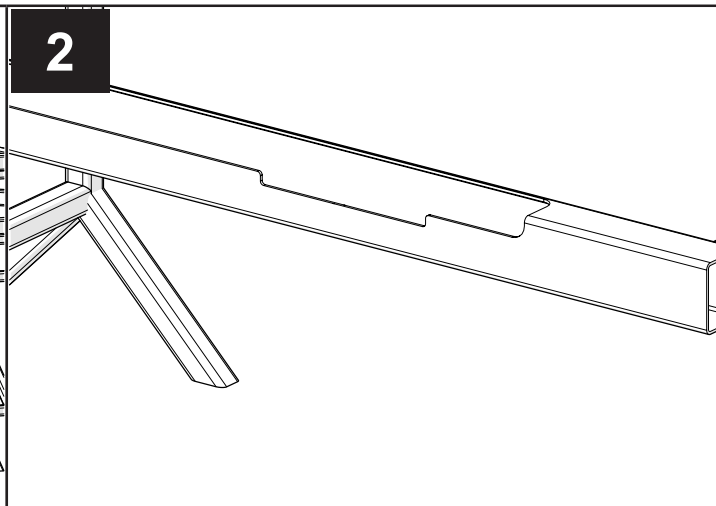
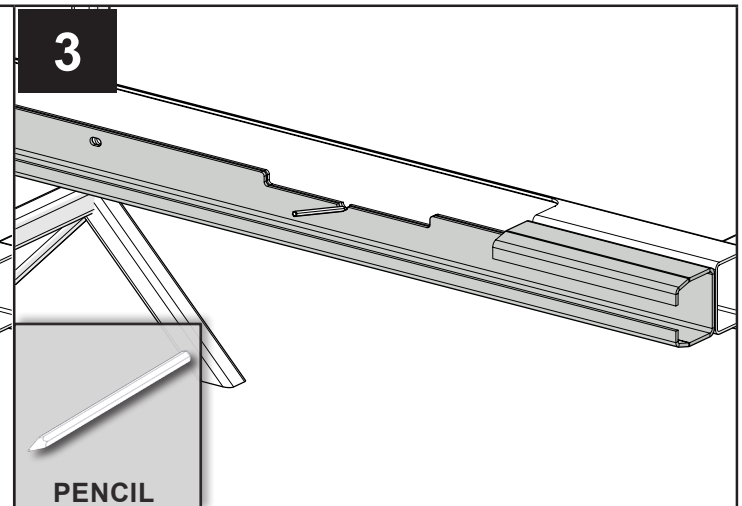
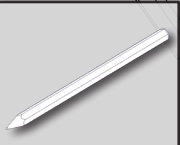
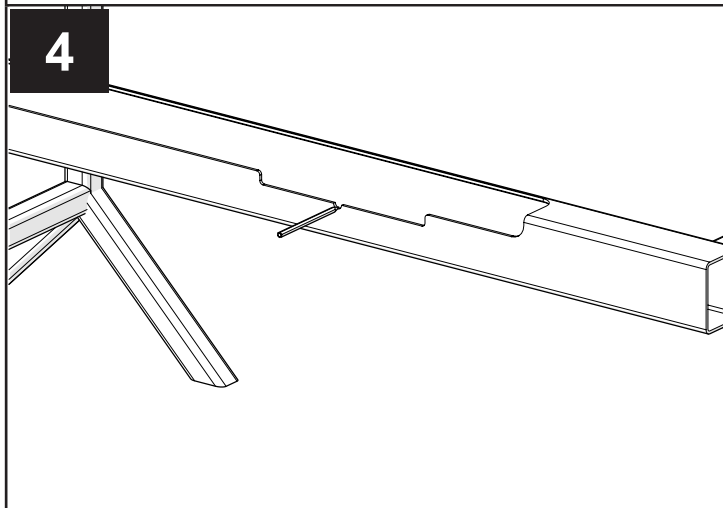
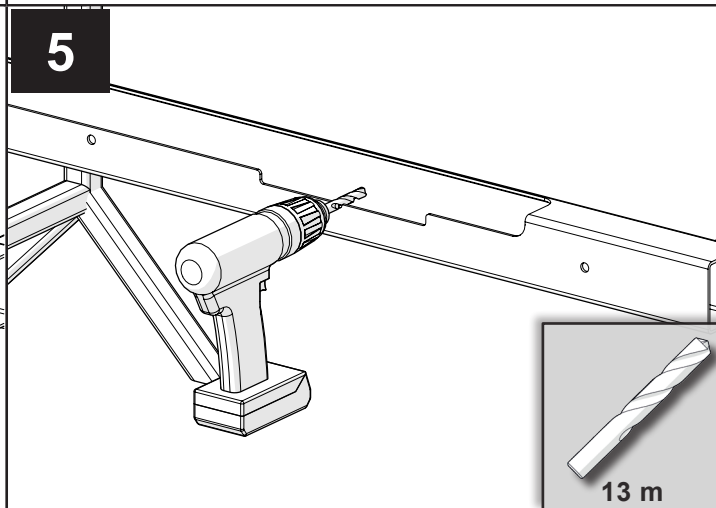
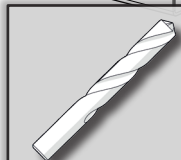
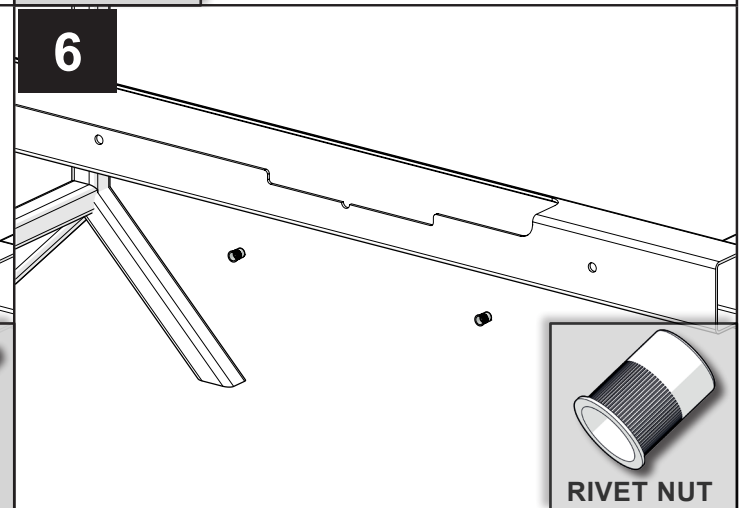
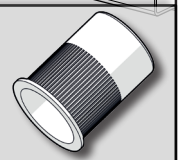
1 	2 	3   PENCIL
4 	5   13 m	6   RIVET NUT

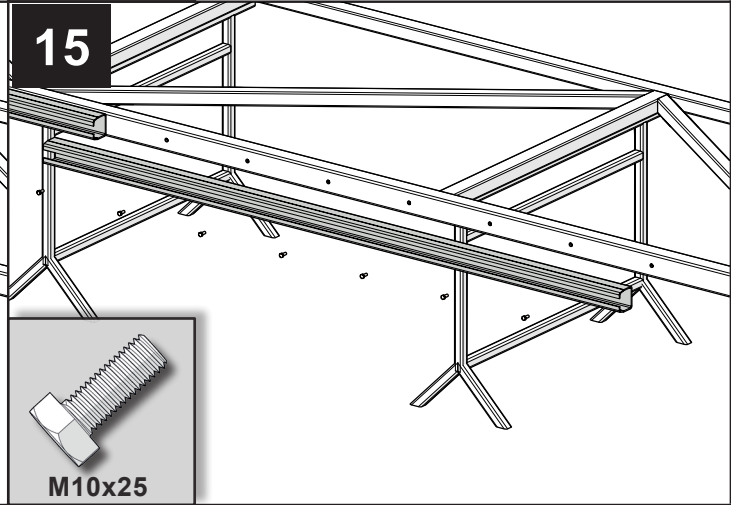
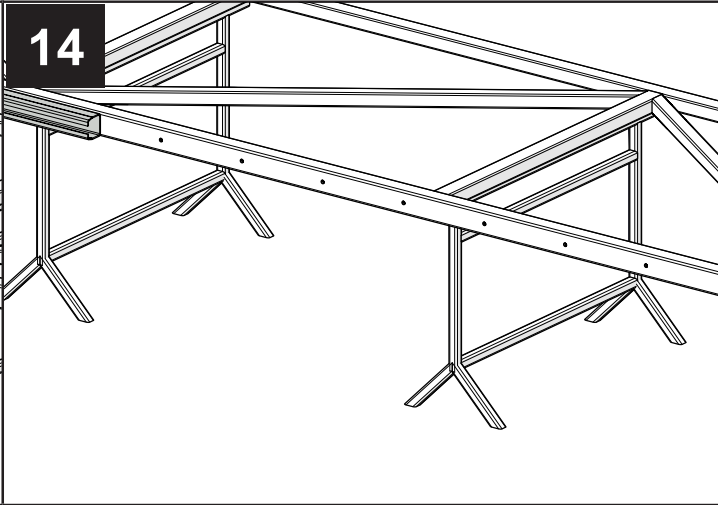
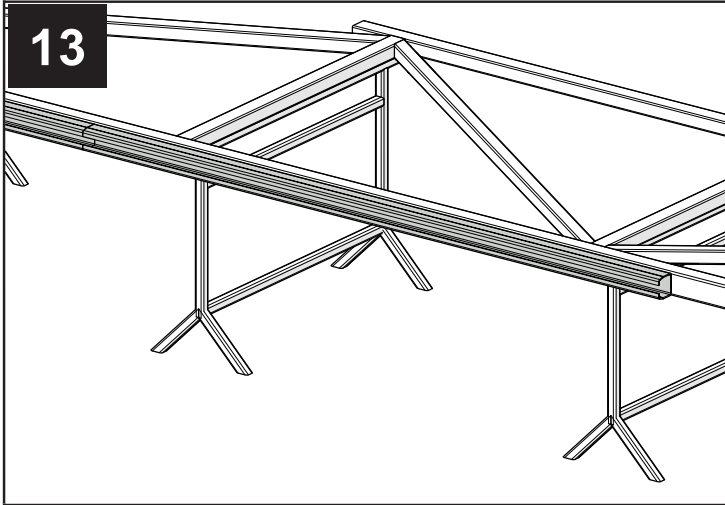
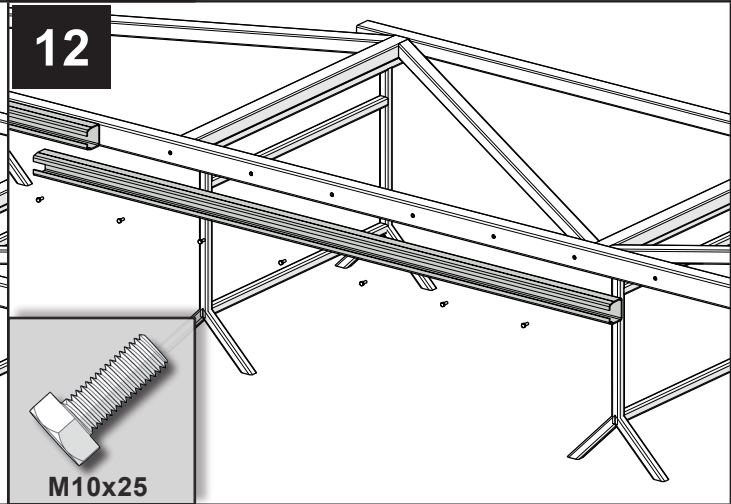
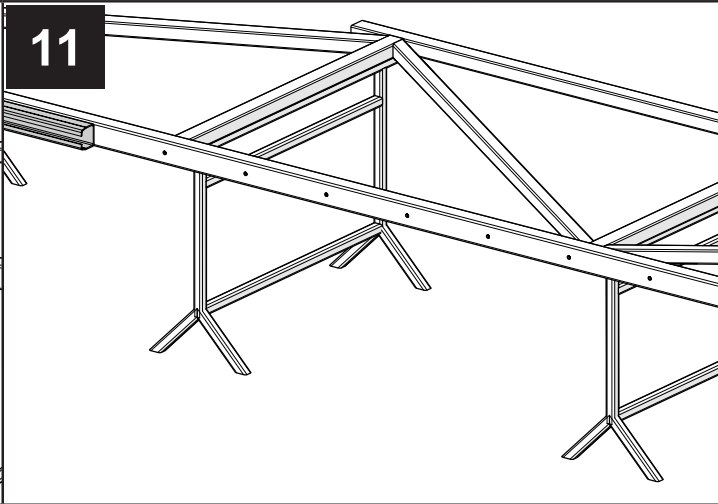
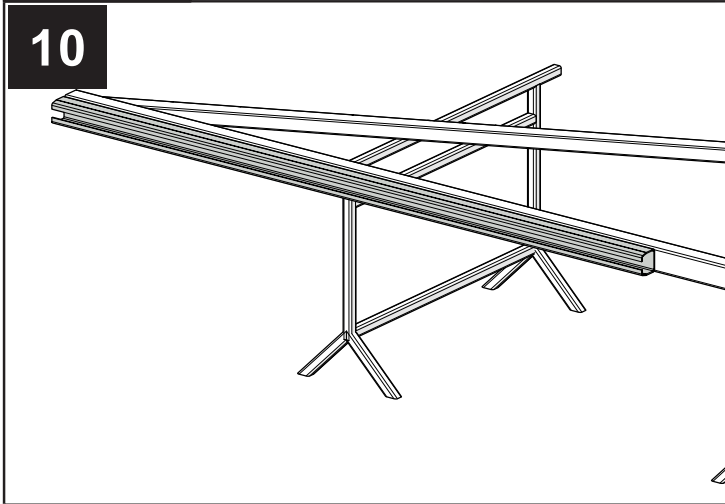
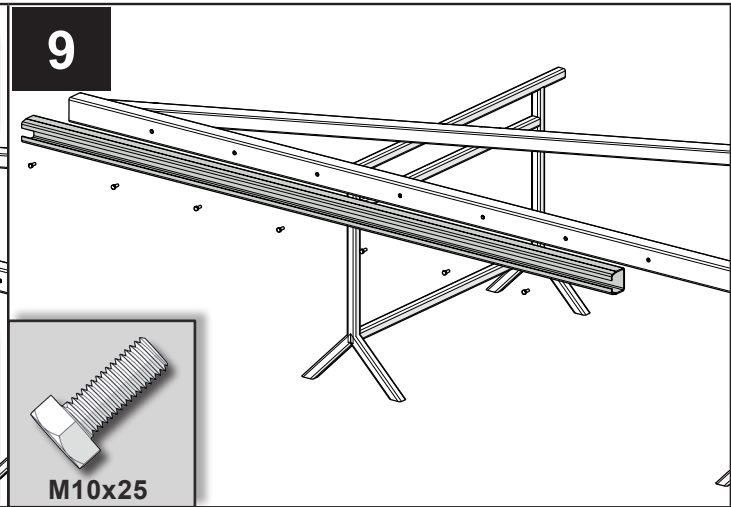
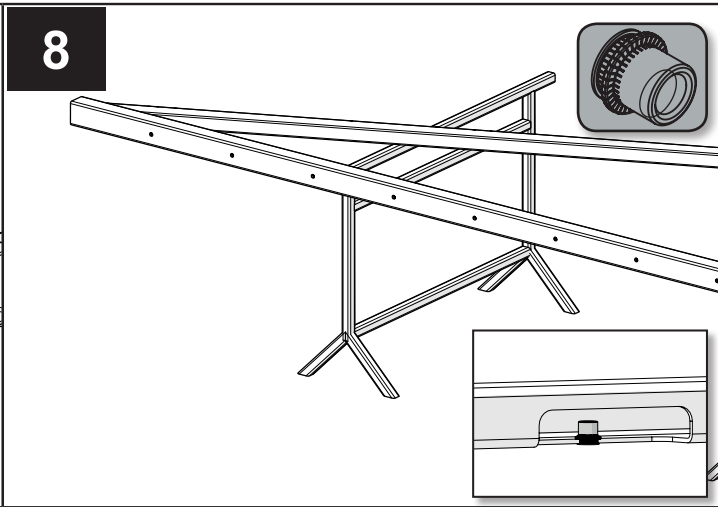
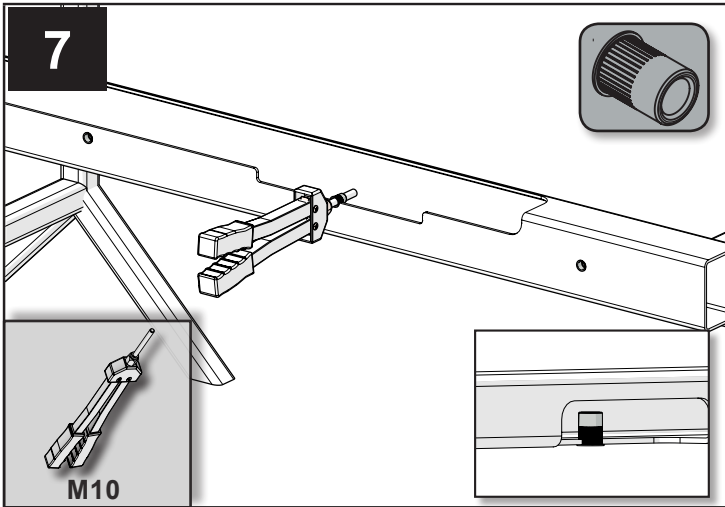

16

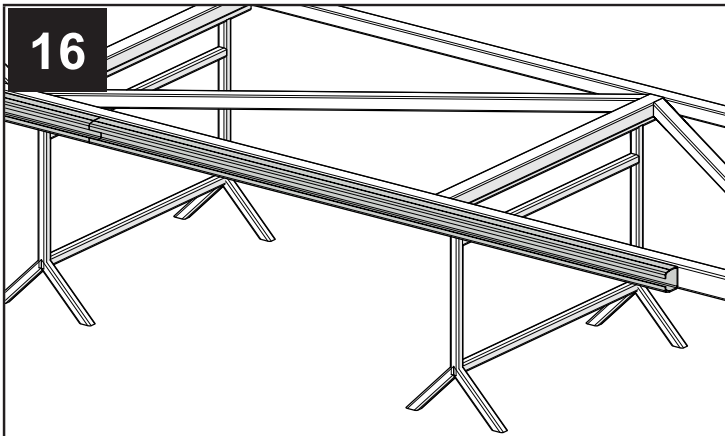

17

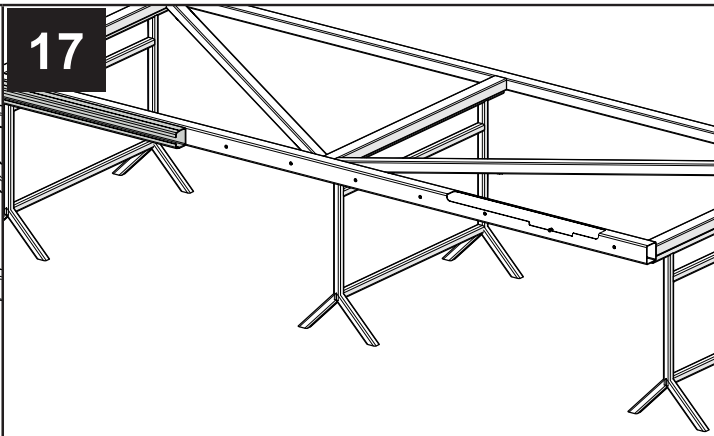

18

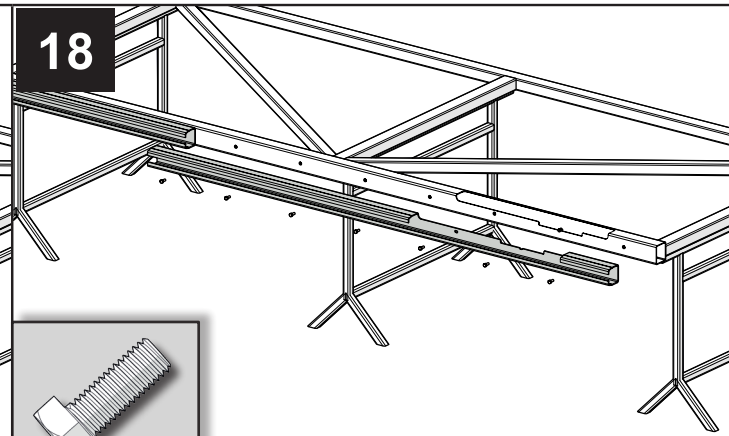

M10x25

19

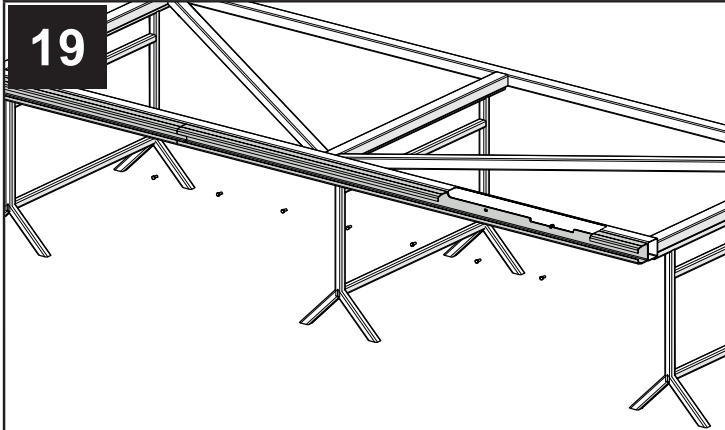

20

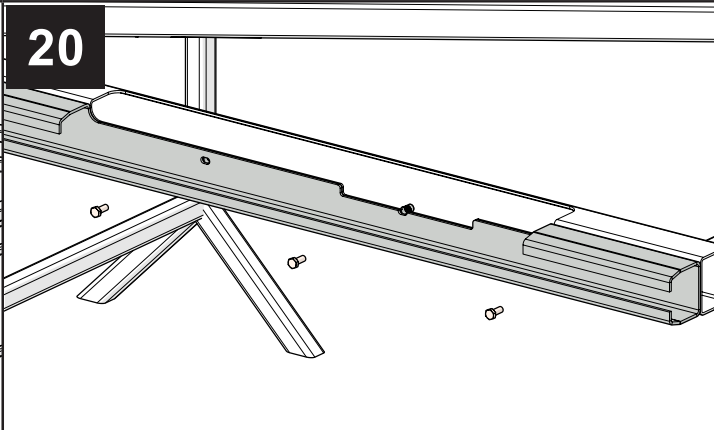

21

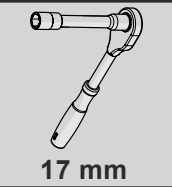
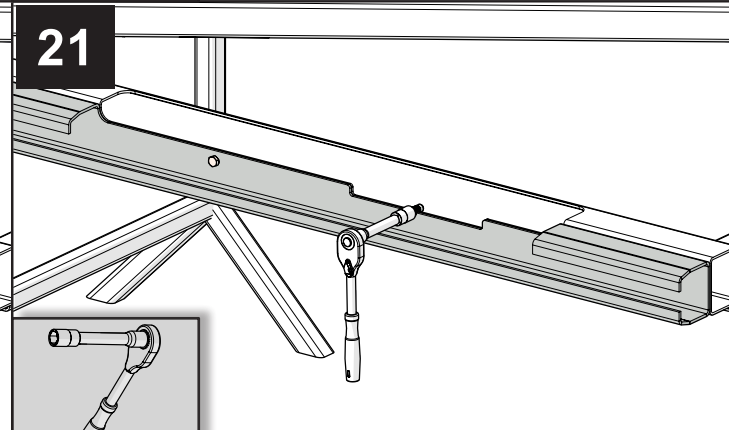

17 mm

22

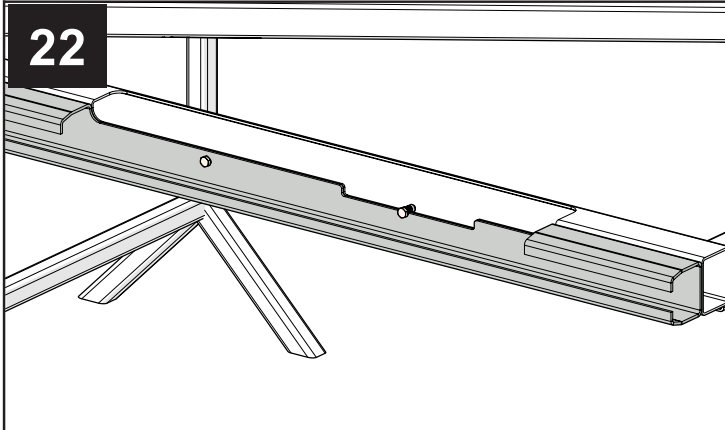

23

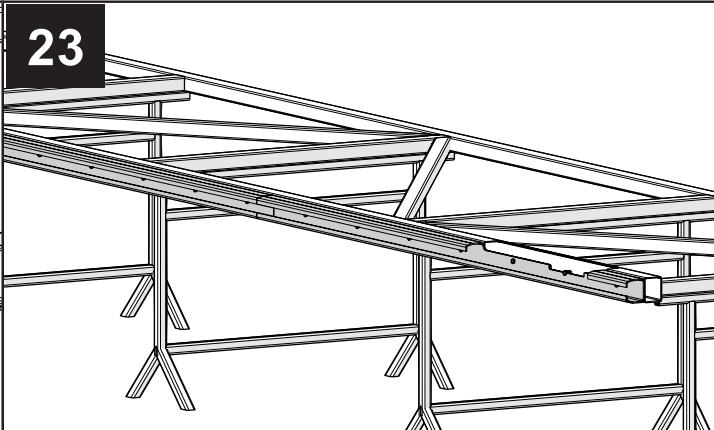

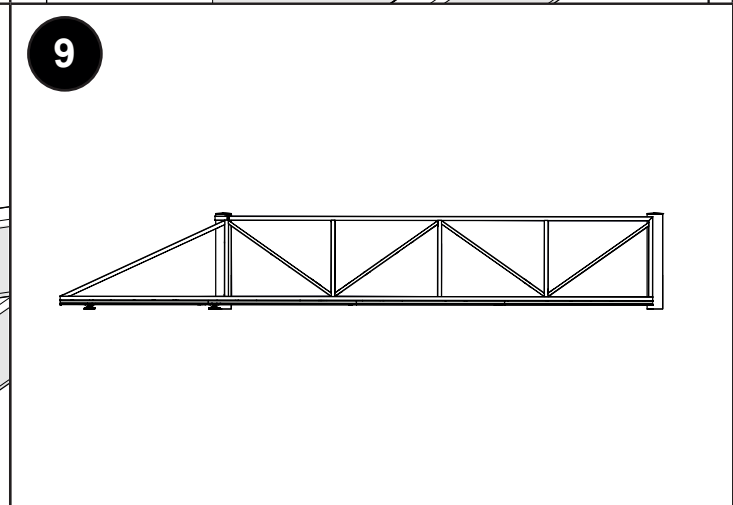
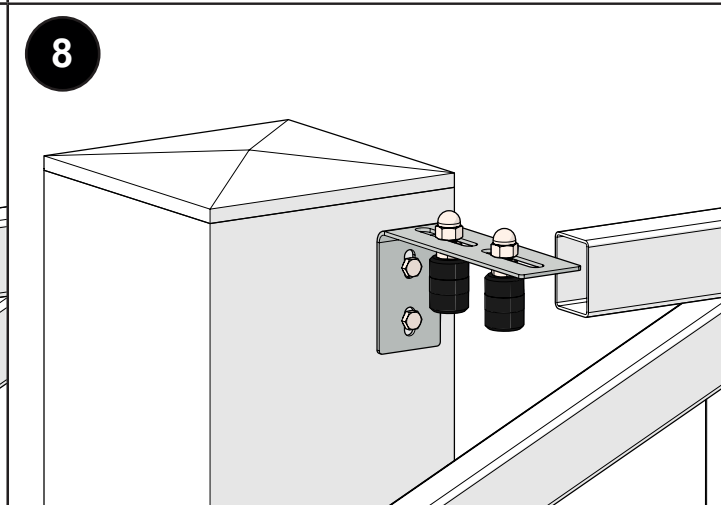
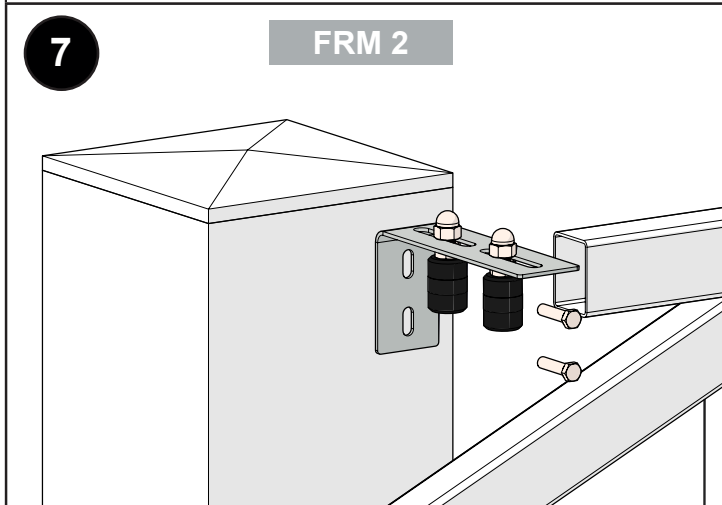
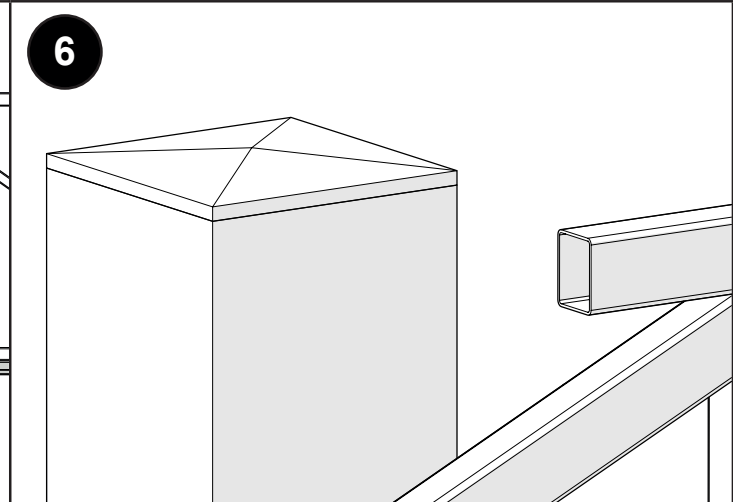
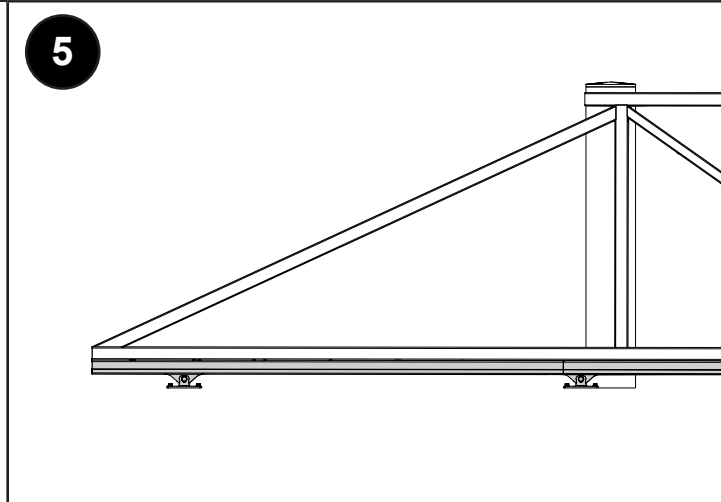
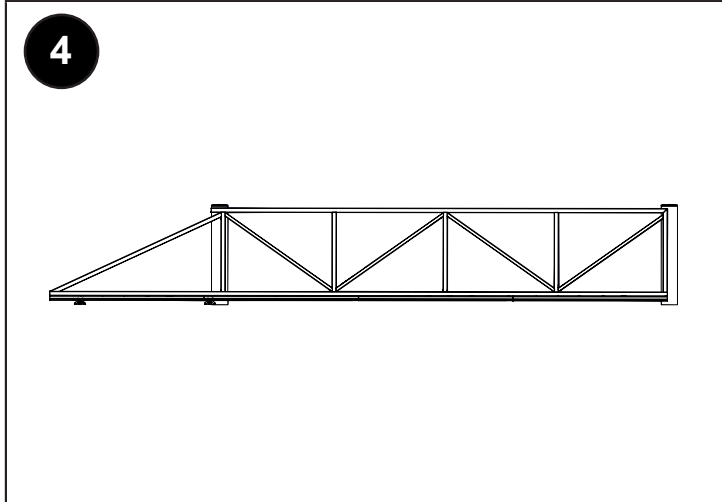
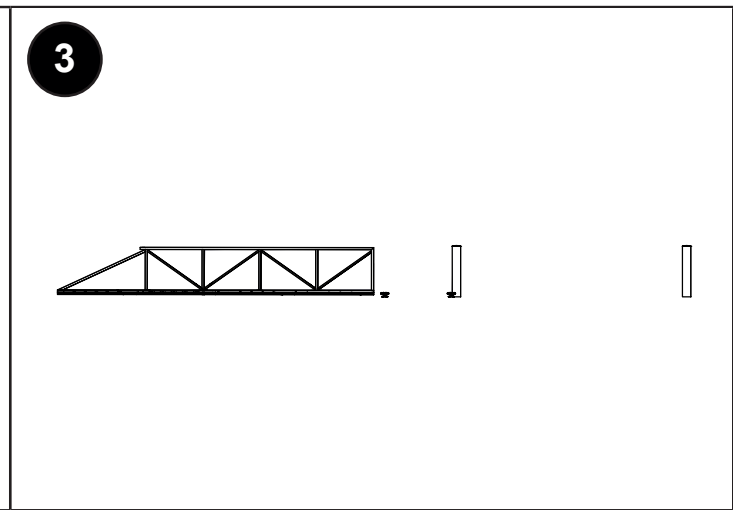
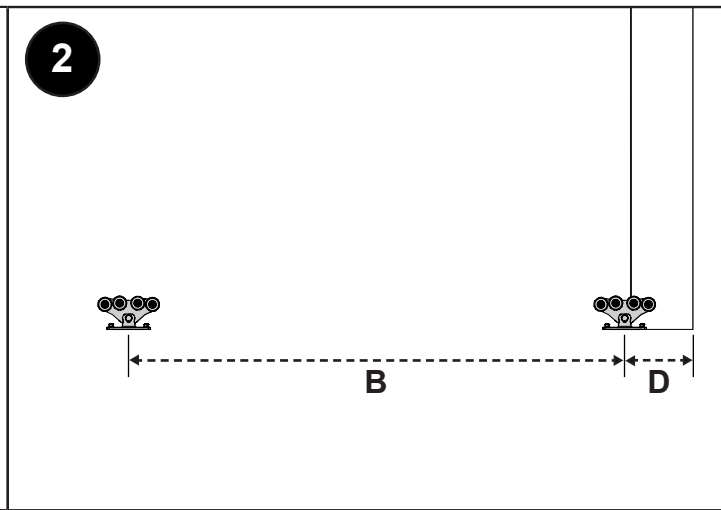
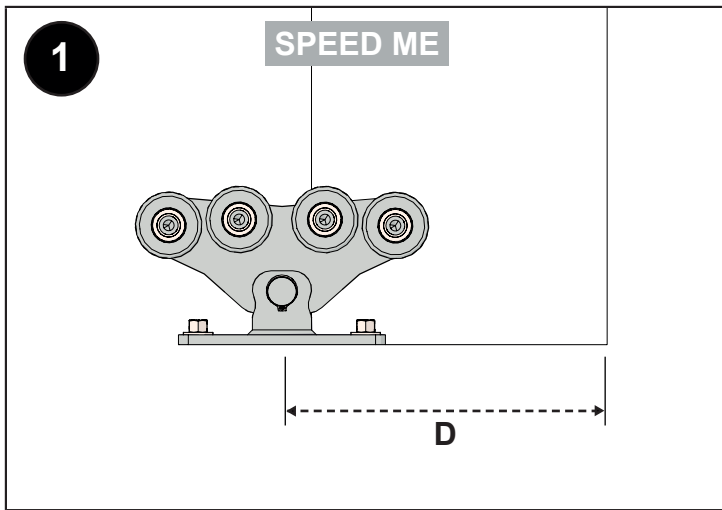

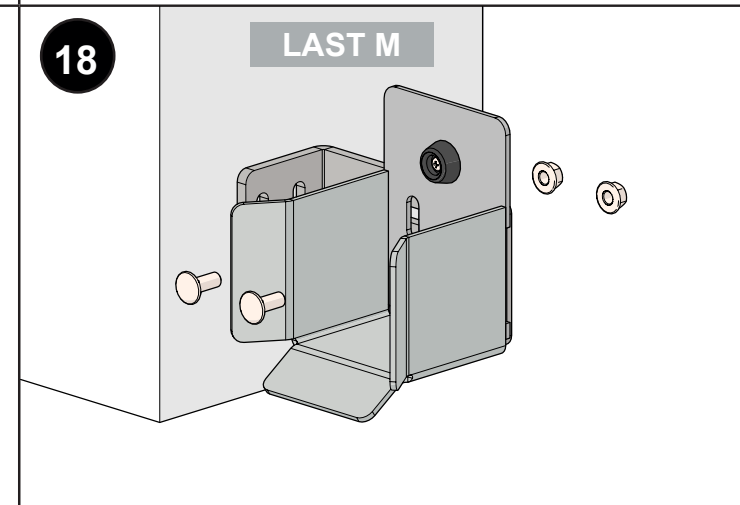
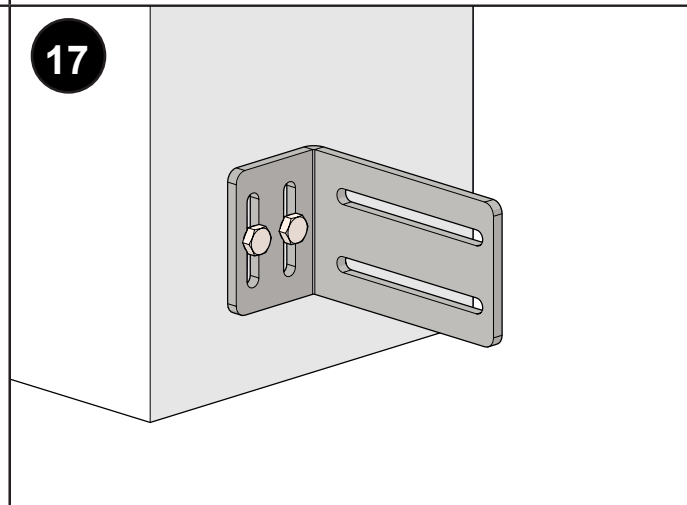
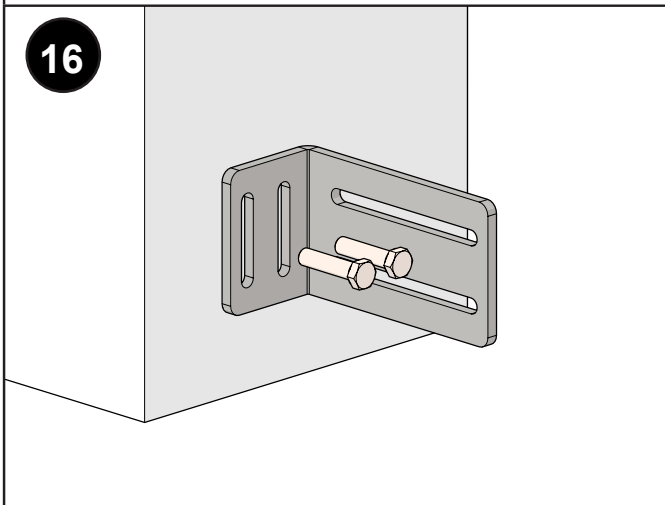
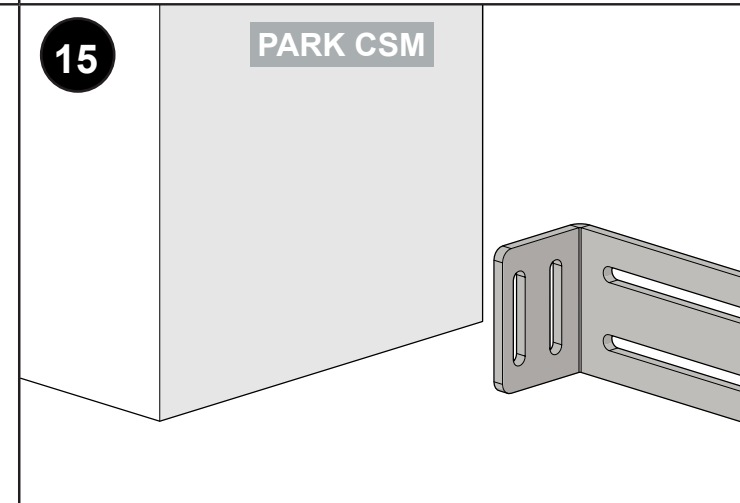
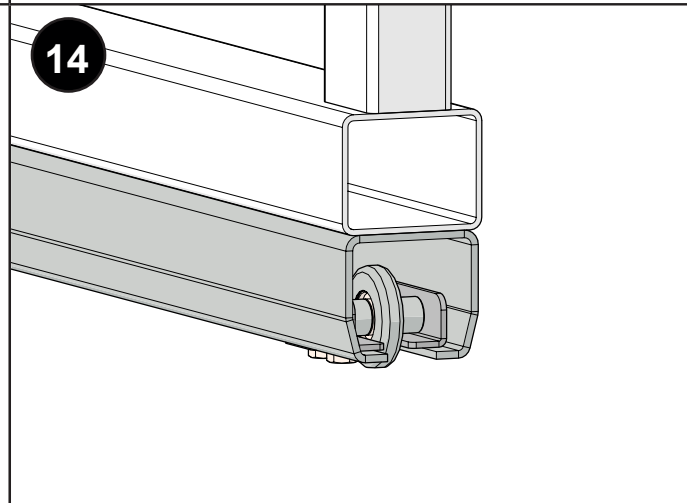
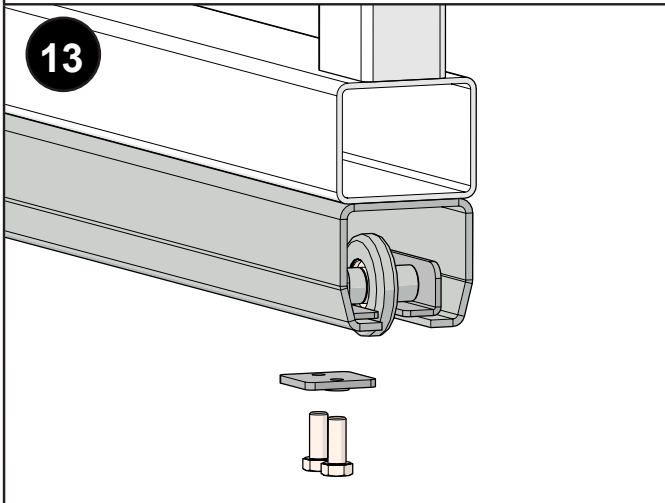
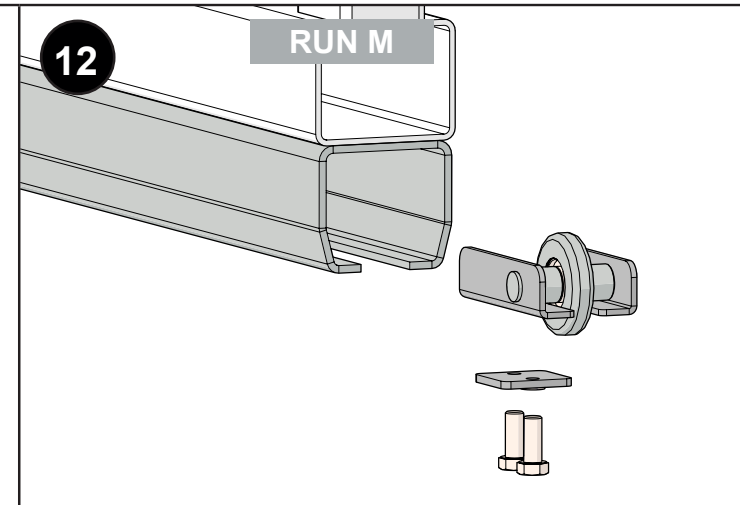
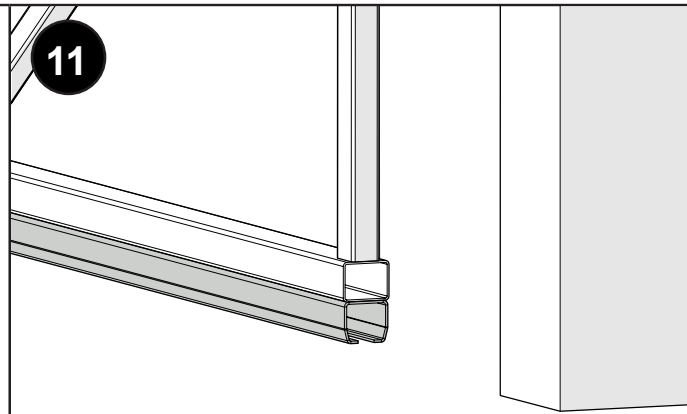
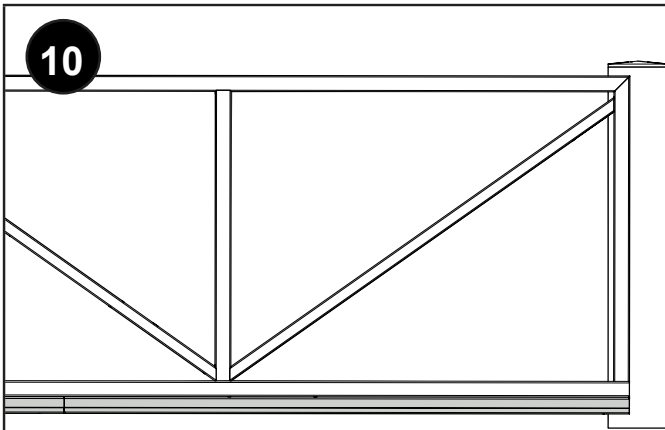

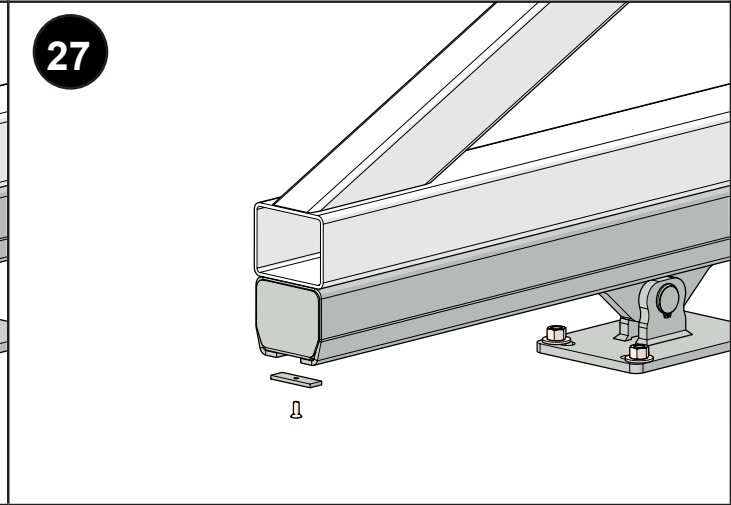
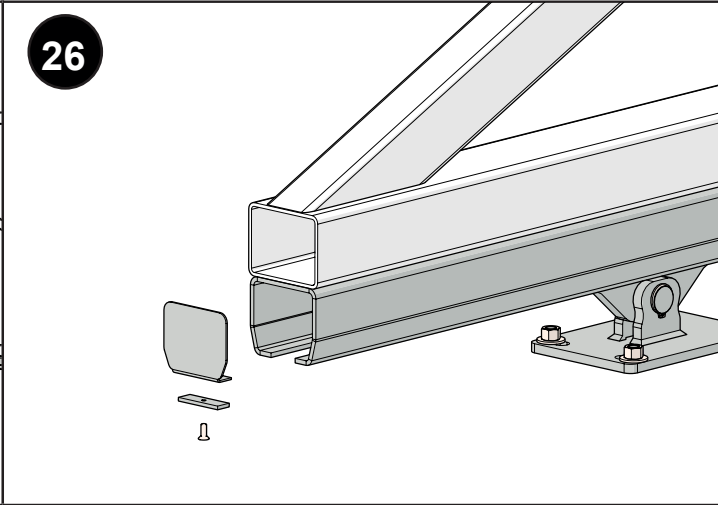
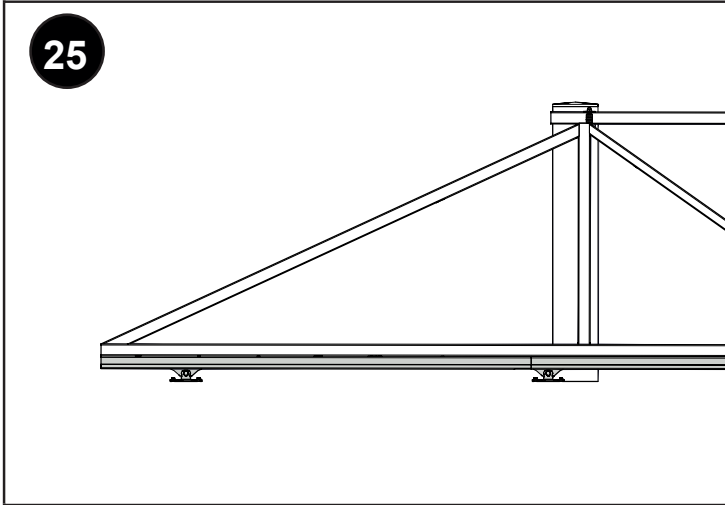
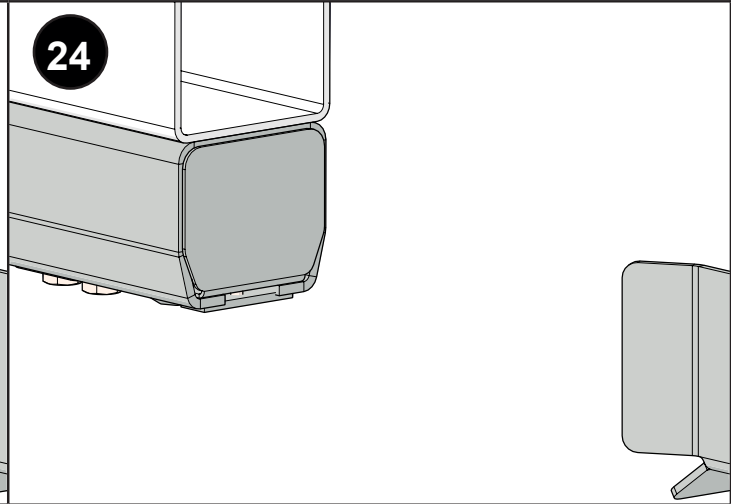
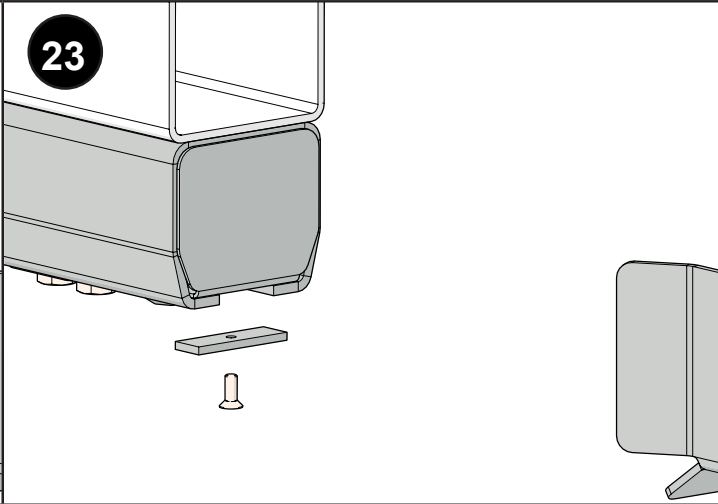
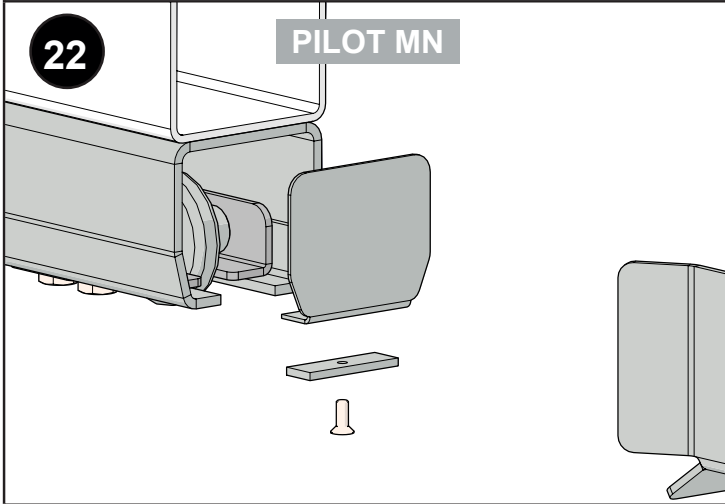
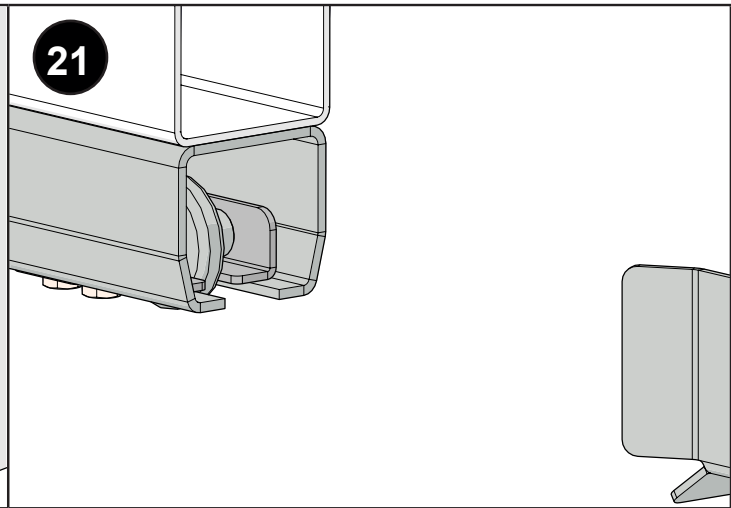
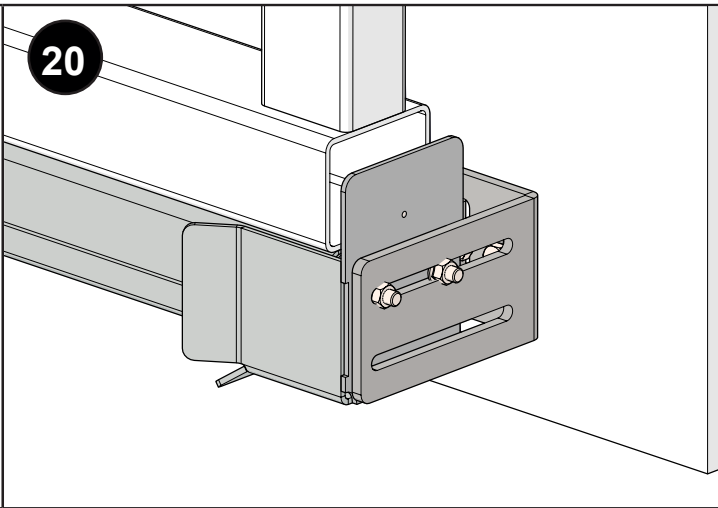
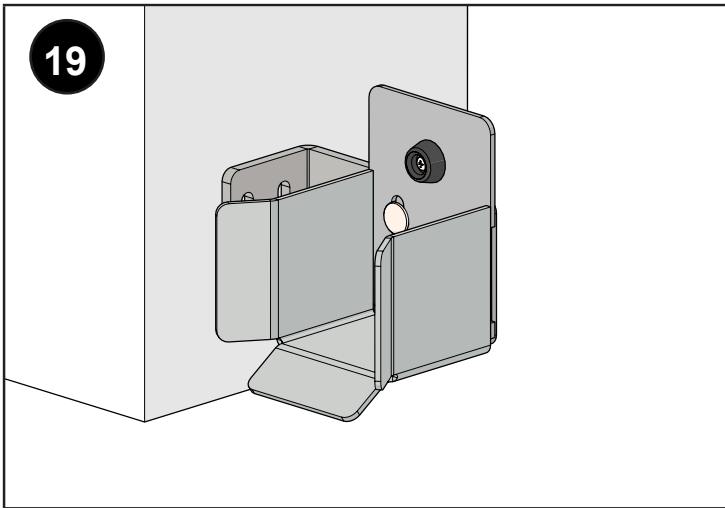

28

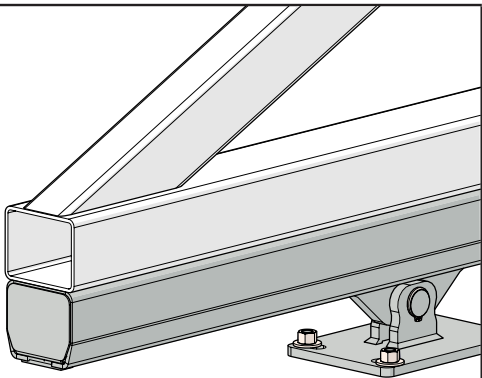

29

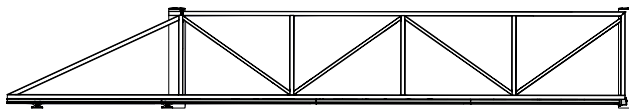



Įmonės kodas: 148167063

PVM mokėtojo kodas: LT481670610

Centrinis Biuras

Žagienio g. 12, LT-36209 Panevėžys

Mob.: +370 612 38009

Tel.: +370 45 586661

Faks.: +370 45 402225

E-paštas: Info@ometa.lt

Vilniaus Biuras

Pramonės g. 12, 14149 Vaidotai

Mob.: +370 615 90067

Tel.: +370 5 2761885

Faks.: +370 45 402225

E-paštas: Vilnius@ometa.lt